

USE OF VIBRATION SENSOR AS DETECTION OF RAILWAY IN MECHANICAL SIGNALING SYSTEMS

Sukenda, S.T., M.T.¹, Wawan Maulana S², Septiane L³, M. Irvan Y⁴, Lukman N. S⁵

ABSTRACT---Interlocking equipment used to secure a system. One of the systems on mechanical signaling that is contained in trains. Mechanical signaling is used to form, lock, and control so that the system is safe from errors that occur in the system. In the world of railroad signaling mechanically it is very much needed so that the train route remains on the correct and safe lane. The railroad to be traversed by the train is carried out mechanically. The development of electronic technology can have an impact on railroad signaling. So that the application of electronic technology can be done on railroad signaling in Indonesia. Rail contact, mechanical signaling that is used to detect the presence of trains. Equipment, rail contacts, to detect the presence of facilities on the railway line at the emplacement. The way rail contacts work uses an iron lever that is in direct contact with the rail wheels so that the movement of the lever causes the switch in the device to be active. Levers that are often stepped on by the train's wheels cause wear. A worn lever causes the level of precision to weaken, making it unsafe for trains to be on the right track. The application of electronic technology, a microcontroller, can replace the worn lever. The SW-420 sensor as a vibration detector is integrated with a microcontroller to determine the presence of a train. This sensor can be applied as a train detector by utilizing vibrations on the rails. From the results of trials conducted, the system with sensors that are built can detect rail vibrations when the railroad stepped on the rail. So that train movement can be detected, and the microcontroller can show the vibration value data in real time.

Keyword---Mechanic Signaling, Rail Contact, SW-420 Sensor, Microcontroller.

I. Introduction

The mass transportation mode, railroad, is a means of railroad with mobile power, both on its own and together. Other railway facilities, which will or are moving on railroad tracks related to train travel. Railroad is also an efficient and effective railroad based land transportation mode. This is evidenced by the carrying capacity either in the form of humans or goods that are greater than other land transportation modes.

The superiority of railroad transportation services is more competitive, in the framework of equitable service to all levels of society. This mode of transportation can improve consumer services in mobility. This mode of

^{1,2,3,4,5,6}Department of Informatics, Faculty of Engineering, Widyatama University
Cikutra Street No. 204A Bandung
email :

¹kenda@widyatama.ac.id, ²wawanmaulana.wm@gmail.com, ³septiane.lathifah@widyatama.ac.id, ⁴mochamad.irvan@widyatama.ac.id,
⁵n.sluki@gmail.com,

transportation provides comfort for passengers. The mode of transportation, train, must be guaranteed security, safety and reliability of both facilities and infrastructure.

One of the infrastructures to ensure the safety of train travel is signaling equipment. Railway signaling equipment is a train operating facility that serves to provide instructions or cues in the form of color, light or other information with certain meanings. The railroad signaling system has a vital function to regulate train operations efficiently and effectively (LIPI, 2012).

According to the railroad researcher from the Technical Implementation Unit (UPT) of the LIPI Instrumentation Development Center, Taufik Hidayat. There are several general requirements in the railroad signaling system. The requirement is the safety principle or failsafe which means there is no damage to the signaling system which can pose a danger to the train users.

Signals must also have high obstacles in giving aspects or signs that are not in doubt and must be easy to maintain. In addition, the sequence of the signal placement along the rail line must be in a standard order so that drivers can understand the path to be traversed, and must be protected by lightning protection (LIPI, 2012).

Selain sistem persinyalan, keamanan perjalanan kereta api juga didukung dari sistem pendeteksi sarana perkeretaapian. Pendeteksi sarana perkeretaapian merupakan peralatan untuk mendeteksi keberadaan sarana pada jalur kereta api baik di emplasemen maupun di petak jalan.

In addition to the signaling system, railroad travel security is also supported by the railway facility detection system. Railway facility detector is equipment to detect the presence of facilities on the railroad tracks both in the emplacement and in the road plots.

At this close distance, the resulting bending motion becomes very small. So that the wheels of the train touch the rail contact iron lever and deliver electric current connected to the electric plane in the station signal house (Soeparno, 1977).

In previous studies, the SW-420 vibratory sensor module as a vibration detector was used for earthquake vibration monitoring systems. The earthquake monitoring system requires a sensor system that has a high distribution, and has ease in the installation process. This sensor module has the elements of excellence above and the sensor installation process is easy (Saputra, Rosmiati, & Sari, 2018).

In other studies, the SW-420 vibrating sensor module is also used in automatic railroad crossing systems. In its design, the SW-420 vibratory sensor module is used to detect vibrations generated by the train when the train passes through the vibration sensor.

The focus of research is to apply the SW-420 sensor module as a train detector utilizing vibrations by using microcontroller tools that are applied to the railroad mechanical signaling system. This device is a series of communication systems between information and sensors, detect events and make decisions by the system.

If the sensor has detected a vibration that exceeds the limit specified in the program, then information will be sent to the microcontroller which will be forwarded to the relay module so that it can provide an indication of the form of an LED light and the buzzer alarm sounds, indicating that the train has been detected. The value of the amount of vibration produced by the sensor will be displayed using LCD (Liquid Crystal Display).

II. Formulation of the Problem

Based on the problem that has been explained in the background part of the problem, then the problem can be formulated as follows:

1. How to design and build a train detection device on the existing mechanical signaling system?
2. How to process the SW-420 sensor module reading using a microcontroller device and send the output to the buzzer alarm, led lights and LCD (Liquid Crystal Display)?
3. How to display data on the results of the amount of vibration produced on the sensor with LCD (Liquid Crystal Display)?

III. Purpose

The purpose of the microcontroller device on the problem that has been explained in the background section of the problem, as follows:

1. Designing and building an electronic presence detection device in the form of a microcontroller device that is integrated in the mechanical signaling system.
2. The sensor reading process uses a microcontroller device and sends output to the buzzer alarm, led lights and LCD (Liquid Crystal Display).
3. Displays the results of vibration detection produced by the sensor with the LCD module (Liquid Crystal Display).

IV. Scope of Problem

Restricted devices are built only to detect rail vibrations produced by railroad movements and are limited to the following:

1. Using Arduino Uno as a microcontroller.
2. Using the SW-420 sensor module as a vibration detector.
3. Using a one channel relay as an output drive mechanism on mechanical signaling.
4. Using buzzer and led as an indication of alarm and lights.
5. Using LCD (Liquid Crystal Display) as a data viewer the amount of vibration produced.
6. The voltage source uses a 12 volt dc accumulator.
7. Testing is done using manual vibration simulation as a rail vibration simulation.
8. The device is produced in the form of a prototype.

4. Operational definition

The operational definition used is as follows, as a reference in conducting research.

Arduino UNO

Arduino is an electronic kit or open source electronic circuit board in which there are main components, namely a microcontroller chip with AVR type from the company Atmel. The purpose of the microcontroller is to read the input by processing it to cause output.

Sensor Module SW-420

SW-420 sensor module is a sensor to detect vibrations, the way this sensor works is to use 1 metal float that will vibrate in a savings containing 2 electrodes when the sensor module receives vibration / shock. There are 2 outputs, digital output (0 and 1) and analog output (voltage).

Relay

Relay is a switch (switch) that is operated electrically and is an electromechanical component (electromechanical) which consists of two main parts namely electromagnet (coil) and mechanical (a set of contact switches / switches). Relays use electromagnetic principles to move the switch contacts so that with a small electric current (low power) can conduct higher-voltage electricity.

LCD (*Liquid Cristal Display*)

Electronic display is an electronic component that functions as a display of data both characters, letters or graphics. LCD (Liquid Cristal Display) is one type of electronic display made with CMOS logic technology that works by not producing light but reflecting the light around it to the front-lit or transmitting light from back-lit. LCD (Liquid Crystal Display) functions as a data viewer in the form of characters, letters, numbers or graphics.

Buzzer

Buzzer is an electronic component that is included in the transducer family, which can convert electrical signals into sound vibrations. Another name for this component is called a beeper. In everyday life, it is generally used for alarm clocks on clocks, house bells, hazard warning devices, and so on. The type of buzzer that is often found is the piezoelectric type. Because this type has advantages such as the relatively cheap price, it is easy to apply to electronic circuits.

Stepdown

Stepdown module is an integrated circuit module / integrated circuit that functions as a step-down DC converter with a current rating of 3A. There are several variants of this IC series that can be grouped into two groups, namely an adjustable version whose output voltage can be regulated, and a fixed voltage output version whose output voltage is fixed.

Led

LEDs are electronic components that can emit monochromatic light when applied forward voltage. Led is a family of diodes made from semiconductor materials.

V. Research Methods

Systems analysis uses data flow oriented methods. Conduct analysis starting from the workings and system requirements, conducting a search for references in research journals that have been done previously, and conducting system development using the waterfall model which is divided into several stages. Next will be the design of the tool used in making a train vibration detection system based on analysis and system requirements. Figure 1 research method used.

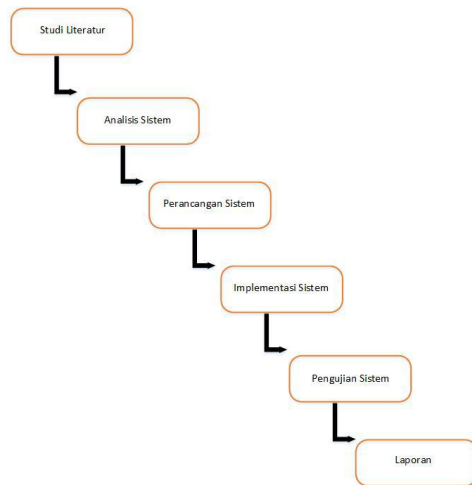

Figure 1: Research Method

Theory.

Arduino Uno

Arduino is a microcontroller minimum board system that is open source. In the Arduino circuit there is an AVR AT Mega 328 series microcontroller which is a product from Atmel. Arduino has its own advantages compared to other microcontroller boards in addition to being open source, Arduino also has its own programming language in the form of C language.

In addition, the Arduino board itself has a USB loader which makes it easier for us when we program the microcontroller inside the Arduino. Whereas on most other microcontroller boards that still need a separate loader circuit to enter the program when we program the microcontroller. The USB port in addition to the loader when programming, can also function as a serial communication port. Figure 2 microcontroller devices used.



Figure 2: Arduino Uno

Sensor Module SW-420

SW-420 sensor is a vibration detector that reacts to vibrations from various angles. In static / no vibration conditions, electronic components function like switches that are normally closed and conductive, whereas in shock (exposure to vibration) the switch will open / close with a switching frequency proportional to the frequency of shocks. This fast switching is similar to the workings of PWM (pulse width modulation) which is a pseudo-analog signal in the form of a voltage level which is then compared by an LM393 (Voltage Comparator IC) integrated circuit with a comparative voltage threshold value (threshold) regulated by a resistor external. Figure 3 is a SW-420 sensor.

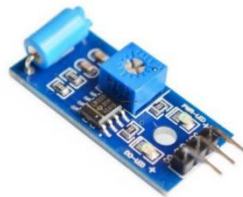

Figure 3: SW-420 Sensor

VI. Analysis and Design Flow

Vibration is a special form of motion. Vibration is a force that is in harmony when reflected and released, vibration can also be interpreted as alternating motion around the equilibrium. The equilibrium here is where the object is in a stationary position if there is no force around the object (Satriawan, 2019).

The train when driving provides vibrations around it. The term vibration that occurs in the train can be interpreted about the phenomenon of hunting oscillation (Hunting Oscillation). The main cause of trains to vibrate when driving is because trains have strong thrust so they are able to provide vibrations that go back and forth with speed, especially the attached wheels which go hand in hand simultaneously produce very fast and strong impulses, these impulses which create vibrations in the train when walking (Soemitro, 2016).

Thus the vibration of the train can be used to detect train facilities by applying the function of the vibration sensor module combined with a microcontroller. Analysis of determinants of vibration levels that will be used to analyze whether these vibrations originate from the movement of trains or other vibrations other than trains are listed in table 1 below.

Table 1: Vibration Level Analysis

No	Getaran	Keterangan
1	≤ 100.000	Bukan Getaran Kereta Api
2	≤ 200.000	Bukan Getaran Kereta Api
3	≤ 300.000	Bukan Getaran Kereta Api
4	≤ 400.000	Bukan Getaran Kereta Api
5	≥ 500.000	Getaran Kereta Api

The proposed system design flow to develop a train vibration detection device which is divided into three parts, namely Input, Process, and Output. The flow of design can be seen in table 2 below. The design flow explains the sequence in designing a train detection system using a microcontroller. The microcontroller is used as a train to detect the existence of the train system as the development of electronic technology to replace the lever.

Table 2: System Design Flow

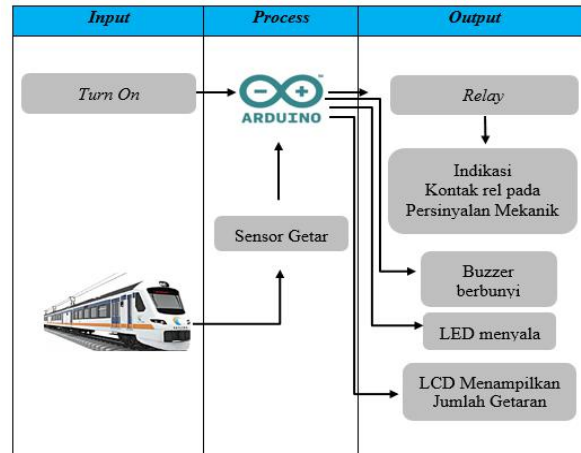

System Design

The system design scheme that will be used in the application of the vibrating sensor as a train detector on the mechanical signaling uses a microcontroller as the main component, the SW-420 vibration sensor module, and supporting components in this system include the stepdown module, relay, LCD (Liquid Crystal Display) in combination potentiometer and LED indication and buzzer with the main voltage source is accumulator 12vdc. The following system design circuit scheme, in figure 4.

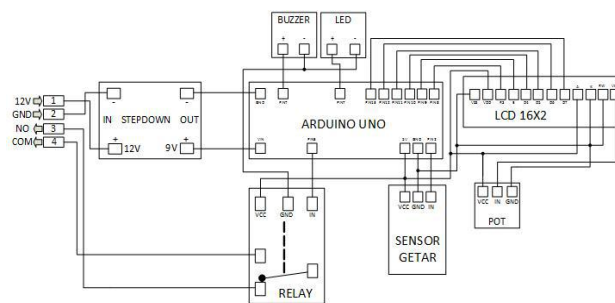

Figure 4: System Circuit Schema

System Block Diagram

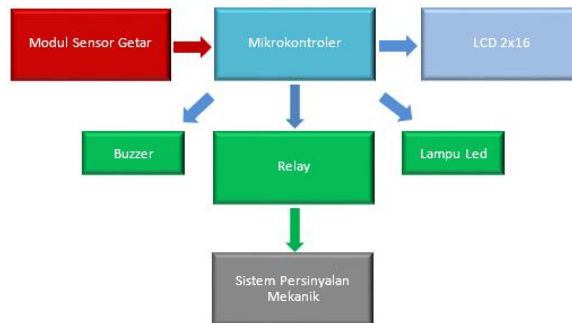

Figure 5: System Block Diagram

VII. System Workflow

A workflow is created to define the automatic movement of a system on a device through a sequence of actions or tasks related to the data processing process on the microcontroller. Figure 6 shows the workflow of the railroad detection system.



Figure 6: System Workflow

Starting with initializing the SW-420 vibrating sensor. After that the sensor will record the vibration data based on vibrations generated from the movement of the train. The recorded data obtained by the sensor will be sent to the microcontroller and displayed on the LCD (Liquid Crystal Display).

If the resulting vibration data has exceeded a predetermined limit, then the indication of the led light is on and the buzzer alarm sounds to further activate the relay and automatically move the mechanism on the mechanical signaling system. Conversely, if no vibration is detected or the resulting vibration record data does not exceed a predetermined limit, then the vibrating sensor will return to perform vibration data recording.

Analysis of system requirements is very necessary for the needs analysis process when creating a system. In addition to the description of the above needs, functional and non-functional requirements are also needed to support the functioning of the system.

Functional requirements analysis is a series of system functions that run through a series of processes. Functional requirements analysis is also a stage of identifying the needs of a system that will be built with the aim of understanding all the needs of the tool to be made. Here are some functional requirements on the device to be made:

a. Functional Requirements

1. Using an Arduino Uno microcontroller as the main control on the device.
2. Using the SW-420 vibration sensor module as a vibration detector.
3. Using a relay as a switch that connects the detection device with the output of the mechanical indication on the mechanical signaling system.
4. Using the LED lights and buzzer as a sign when the system is working and detecting vibrations, the two components can be active simultaneously.
5. Using the LCD (Liquid Crystal Display) to monitor the amount of vibration data generated
6. The power supply used for the device uses 12 volt dc electric power, where the electric power works in parallel as an input of electric current on mechanical signaling indications and also the input in the detection system with a voltage divider using a stepdown module.

b. Non-Functional Needs

1. The system is designed in such a way as to make it easier to use.
2. Material used as a board or holder of the detection system uses a plastic / acrylic box.

System Design

System design is a combination and integration of modules and devices as well as the main components and supporting components used in the design of train vibration detection systems in mechanical signaling systems by applying the SW-420 vibrating sensor module using a microcontroller. Figure 7 detection system design.

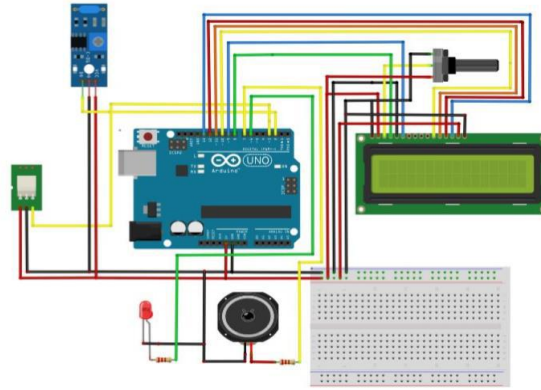

Figure 7: Detection System Design

System Testing

The purpose of the test is to find out and analyze the value of vibration produced for the application of the SW-420 vibrating sensor as a train detector in a mechanical signaling system using a microcontroller. In the simulation test of vibration samples on the detection device using the SW-420 vibrating sensor, the following table contains the results of the test results from train vibrations. Table 3 results of vibration tests taken.

Table 3: Vibration Sample Test Results

No	Batasan Minimal Getaran	Pembacaan Nilai Getaran	Status Relay, Buzzer, dan Led
1.	300.000	4	Tidak Aktif
2.	300.000	138	Tidak Aktif
3.	300.000	575	Tidak Aktif
4.	300.000	516.467	Aktif
5.	300.000	639.374	Aktif
Jumlah Getaran Aktif			1.155.841
Jumlah Getaran Aktif dibagi Total Percobaan Getaran Aktif			577.920,5
Rata-rata getaran			≈577.921

Seen from table 3 that the SW-420 vibrating sensor can read vibrations and can activate relays, buzzers, and led if the vibration data exceeds the minimum vibration limit specified in the program. Data on the amount of vibration produced depends on the level of sensor sensitivity.

In this test, it can be seen the number of active vibrations produced reached 1,155,841. The amount is taken from the total vibration that can activate the detection system device.

Judging from the results in table 3, the average vibration is taken from the total amount of active vibration data divided by the number of active vibration experiments. So as to produce an average minimum vibration value of 577,921 which can be implemented and used as a reference to determine the minimum vibration value in the program as a result of vibration from train movements.

VIII. Conclusion

1. Development and design of the train detection system has been carried out by applying the SW-420 sensor module as a vibration detector with a combination of other supporting components.
2. In processing the sensor module reading using an Arduino microcontroller device has been done and can function to detect the presence of vibrations.
3. The system can display the results of the detection of the amount of vibration data on the sensor using the LCD (Liquid Crystal Display) and can send output commands to activate the relay, turn on the LED lights and sound the buzzer alarm.

REFERENCES

- [1] LIPI, H. (2012, Juli 5). Sistem Persinyalan Berperan Vital dalam Efektifitas dan Efisiensi Layanan Kereta Api. [Online]. Accessed 7 Januari 2019. <http://lipi.go.id/berita/single/Sistem-Persinyalan-Berperan-Vital-dalam-Efektifitas-dan-Efisiensi-Layanan-Kereta-Api/7243>
- [2] Saputra, Julio Fajar; Mia Rosmiati; Marlindia Ike Sari (2018). Pembangunan Prototype Sistem Monitoring Getaran Gempa Menggunakan Sensor Module SW-420. Fakultas Ilmu Terapan, Telkom University.
- [3] Kusriyanto, Medilla; Nendy Wismoyo (2017). Sistem Palang Pintu Perlintasan Kereta Api Otomatis Dengan Komunikasi Wireless Berbasis Arduino. Yogyakarta, Indonesia
- [4] Jabarullah, N.H. (2019) Production of olefins from syngas over Al₂O₃ supported Ni and Cu nano-catalysts, *Petroleum Science and Technology*, 37 (4), 382 – 385.
- [5] Suharjono, Amin; Eni Dwi Wardihani; Yossy Febryana Kusuma Hardani (2017). Analysis Of The Vibration Signal Detection For Rail Train Arrival. Semarang, Indonesia
- [6] Fauzi; Mahyuddin; Kurnia Lahna (2017). Pemanfaatan Module GSM (Sim 900) Berbasis Arduino-Uno sebagai Sistem Alarm dan Pengunci Pintu Otomatis Jarak Jauh. Aceh, Indonesia
- [7] Wisnu Happy Eko Saputro (2014). Perkembangan Transportasi Kereta Api dan Pengaruhnya Terhadap Industri Perkebunan di Surakarta Tahun 1864-1930. Fakultas Ilmu Sosial, Universitas Negeri Yogyakarta, Yogyakarta
- [8] PT. Kereta Api Indonesia (2015). Peraturan Dinas 13A Jilid 1 Tentang Ketentuan Umum Persinyalan. Bandung, Indonesia
- [9] Eky Yanuar. Persinyalan Kereta Api. [Online]. Accessed 1 Desember 2018. www.academia.edu/7698164/PERSINYALAN_KERETA_API
- [10] Musaini (2017). Analisis Kualitas Layanan Konsumen Terhadap Keunggulan Bersaing Jasa Transportasi Darat Pada PT. Kereta Api Indonesia (persero) Kelas Argo. Fakultas Ekonomi, Universitas Jambi
- [11] Indra Slamet Wahyudi (2017). Mikrokontroler Platform Arduino. Jurusan Teknik Elektro, Universitas Negeri Malang.
- [12] Satriawan, M. Fisika Dasar. [Online]: Accessed 9 Agustus 2019. <http://ku-buku.blogspot.com/2017/11/fisika-dasar-untuk-universitas-mirza.html>
- [13] Soemitro. (2016). Kenapa kereta api selalu bergetar saat berjalan?. [Online]: Accessed 8 Agustus 2019. <https://www.galena.co.id/q/kenapa-kereta-api-selalu-bergetar-saat-berjalan>
- [14] Soeparno. (1977). Teknik Sinyal Mekanik. Bandung.