

Impact of Brand Equity on Patronage and Repurchase Intention of Branded Apparels in Chennai City

V. Devendranath Reddy and Dr.S. Fabiyola Kavitha

***Abstract---** Branding is defined as, establishing an image or reputation in the eyes of customers. The prime purpose of branding is to make your brand exceptional and stands separate among the available brands. Branding may be communicated through corporate color palettes, logo but it is not limited to. Branding also represents store environment, employees, quality, price of the product, advertising and so on. In this paper, the researcher aimed to find out the brand equity and its impact of Repurchase intention of apparel customers of Chennai city. Young customers who age group falls between 18-30 were selected for the study about their preferred brands of apparel for their regular and casual apparel needs. 135 samples were collected and data analysis was carried out using IBM SPSS and AMOS 0.0 packages. The results of the study represents that all the five constructs used in the study namely Brand familiarity, Brand Relevance, Brand Exclusivity, Brand performance, Brand Legacy is having an impact and found to be the drivers of repurchase intention.*

***Keywords---** Brand Equity, Apparels, Chennai, Retail Apparel, Brand, Branding.*

I. INTRODUCTION

Brand Equity is a business-related value which derives the brand perception of the customer. The brand will grow, as a result of customer experiences with the brand. After a good brand experience, there is a lot of scope for repurchase and loyalty intentions.

Branding is a multifaceted process and not so easy. Brand equity has to be effectively managed to improve the operational performance of the business (**Bijuna C. Mohan, 2016**). Consumer satisfaction mediates the relationship between Consumer based brand equity and brand loyalty in the hotel industry, (**Janghyeon Nam, 2011**). The attributes of good brand equity should be outstanding, easily identifiable, trustworthiness, and finer in quality. In this study the researcher collated five dimensions namely Brand Familiarity, Brand Relevance, Brand Exclusivity, Brand Performance and Brand Legacy.

All the five constructs are tested statistically whether they have impact on repurchase intention of customers with reference to branded apparels.

V. Devendranath Reddy, Research Scholar, Department of Management Studies, Bharath Institute of Higher Education and Research, Selaiyur, Chennai, Tamil Nadu. E-mail: devendranathreddy@gmail.com
Dr.S. Fabiyola Kavitha, Guide, Associate Professor, SRM Arts and Science College, Trichy.

II. QUESTIONNAIRE CONSTRUCTS USED IN THE STUDY

Brand Familiarity

The Degree of awareness of consumers about a particular brand. Brand familiarity also deals with the knowledge of the consumers about the brand which is usually measured in a scale. Brand familiarity leads to repeated / impulse purchase.

Brand Relevance

An Incorporated brand should become a part of the everyday life of the consumers. For Ex formal shirts. Ultimate satisfaction and customer experiences will lead to customer loyalty. When brands are more relevant customers are willing to pay more.

Brand Exclusivity

Every brand manager should build a brand, where as customer should be given “Just for me” experience. Most good brands believe in delivering a product or service which consumer desires.

Brand Performance

Popularity and effectiveness of the brand is the outcome of any successful business. The brand performance is the key indicator of brand desirability. Perceived brand delivery, Brand perceptions, brand quality are measured through metrics.

Brand Legacy

Brand Legacy is a phenomena, where by a strong association between brand and product of service will be experienced by the consumer. Legacy is a precious component of brand identity. Being classic has its own advantages in boosting the sales. Successful businesses around the world today is more than 60 years old, which stands archetypal.

Repurchase Intention

The Future intention of buying a particular brand. It is generally a customer statement about the ultimate buying experience which drives towards loyalty. Buying or availing the services from the same brand or same company.

III. REVIEW OF LITERATURE

Relationship marketing strategies and focus on customer satisfaction will foster the brand equity (**Steven A. Taylor et al,2004**). There is a relationship between brand equity and consumer willingness to pay in branded apparel products. The study was conducted using Becker-DeGroot-Marshack model (**Yan Ming Li et al.,2014**). Brand equity can be developed using Corporate Societal Marketing program. The author explored about the importance of brand awareness, brand image, brand credibility and brand feelings. Customers who trust the brand and express their loyalty are willing to adopt to their brand extensions. The author validated the brand equity model using brand performance, brand value, social image, trustworthiness and commitment. According to this study, those products with higher prices found to be scored higher in the empirical test (**Walfried Lassar,1995**). The author

explained the importance of interacting with the customer will create a positive experience and increase the brand value of the customers. Customer experience is having an impact on the constructs of brand equity (**Galina Biedenbach, 2009**) than brand awareness and perceived quality dimensions, brand loyalty is having an effect on brand equity. These results were computed by validating the Aaker's conceptual model. (**Eda Atilgan,2005**)

IV. SAMPLING FRAME AND METHODOLOGY

135 Samples was collected from the young apparel customers of Chennai city. 5-point Likert scale was developed with 24 items ranging from Strongly disagree to Strongly agree. Initially 20 samples were collected to pre test the questionnaire. After checking the content validity, some minor changes made in the questionnaire and samples was collected. Since apparels were more patronized by the youngsters for their fashion needs, younger age group were selected for the study. The Collected samples were statistically analyzed using Statistical package for social sciences and SPSS AMOS. Totally 6 constructs were used in the study out of which Brand Familiarity, Brand Relevance, Brand Exclusivity, Brand Performance and Brand Legacy are the constructs of brand equity. The construct Repurchase intention is the dependent variable of the study.

Hypotheses of the Study

- H1-** Brand Familiarity is having an effect on Customer Repurchase intention.
- H2-** Brand Relevance is having an effect on Customer Repurchase intention.
- H3-** Brand Exclusivity is having an effect on Customer Repurchase intention.
- H4-** Brand Performance is having an effect on Customer Repurchase intention.
- H5-** Brand Legacy is having an effect on Customer Repurchase intention.

Objectives

- To Study the drivers of repurchase intentions and of branded apparel shirts in Chennai city.
- To study the attributes of brand equity this is having an impact on loyalty intention

Table 1: Reliability Statistics

CONSTRUCTS	NO OF ITEMS	ALPHA
BRAND FAMILIARITY	4	0.793
BRAND RELEVANCE	4	0.781
BRAND EXCLUSIVITY	3	0.851
BRAND PERFORMANCE	4	0.899
BRAND LEGACY	3	0.714
REPURCHASE INTENTION	5	0.883

The Cronbach alpha value ensures the internal consistency of the collected dataset. The highest alpha value is observed for the construct Brand Performance is 0.899. Normally the value which is above 0.5 is observed to have satisfactory internal consistency. (See table 1)

Table 2: Descriptive

Descriptive Statistics				
CONSTRUCTS	Mean	Std. Deviation	Skewness	Kurtosis
BRAND FAMILIARITY	3.563	0.829	-0.177	-0.744
BRAND RELEVANCE	3.5463	0.80355	-0.219	-0.628
BRAND EXCLUSIVITY	3.2074	1.14812	-0.358	-0.85
BRAND PERFORMANCE	3.6759	0.75191	-0.5	-0.143
BRAND LEGACY	3.8778	0.63545	-0.594	0.142
REPURCHASE INTENTION	3.6796	0.798	-0.476	-0.494

Brand Legacy is having a mean value of 3.8 which is highest. Brand familiarity and relevance is having a mean value of 3.5. Brand legacy is having a second highest mean value of 3.87. The least mean value is observed for brand Exclusivity. (See table 2)

Multiple Regression

Table 3: Coefficients

Model	Unstandardized Coefficients		Standardized Coefficients		Sig.
	B	Std. Error	Beta	t	
1 (Constant)	.384	.348		1.105	.271
BRAND FAMILIARITY	.482	.094	.501	5.117	.000
BRAND RELEVANCE	-.004	.111	-.004	-.035	.972
BRAND EXCLUSIVITY	-.008	.080	-.011	-.100	.921
BRAND PERFORMANCE	.185	.098	.175	1.882	.062
BRAND LEGACY	.241	.104	.192	2.329	.021

a. Dependent Variable:
Repurchase Intention

Repurchase Intention = 0.384+(0.482*Brand Familiarity) +(-.004*Brand Relevance) +(-0.008* Brand exclusivity) +(0.185* Brand performance) +(0.241*Brand Legacy).

Brand familiarity is having a significant value of 0.000 which is lower than the expected value of 0.05. Brand Legacy is found to be significant (where the p value is 0.021 which is lesser than 0.05). (See table 3)

Table 4: Correlations

	BF	BR	BE	BP	BL	RP
BRAND FAMILIARITY	1					
BRAND RELEVANCE	.759**	1				
BRAND EXCLUSIVITY	.715**	.798**	1			
BRAND PERFORMANCE	.581**	.685**	.742**	1		
BRAND LEGACY	.613**	.544**	.641**	.611**	1	
REPURCHASE INTENTION	.709**	.591**	.596**	.572**	.596**	1

** . Correlation is significant at the 0.01 level (2-tailed).

Repurchase intentions is having a direct linear relationship with all the 5 constructs of brand equity. Brand familiarity and Repurchase intention is having a higher r value of 0.709 followed by Brand Legacy (where r value is 0.596), Brand Exclusivity (0.596), Brand relevance (0.591) and Brand Performance (0.572). (See table 4)

V. STRUCTURAL EQUATION MODELING-CONFIRMATORY FACTOR ANALYSIS

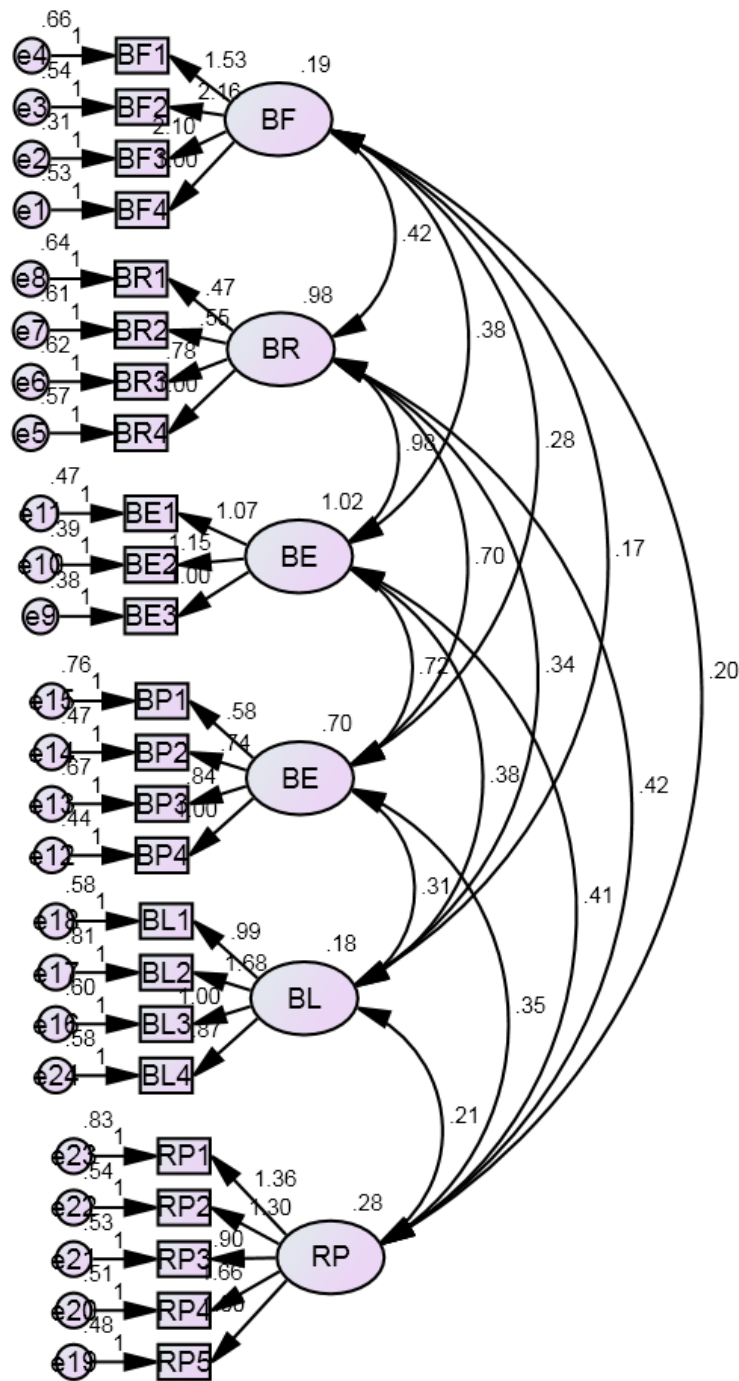

Table 5: Model Fit Indices

A. CFI	B. GFI	C. AGFI	D. RMSEA
Comparative fit index	Goodness of Fit index	Adjusted goodness of fit index	Root Mean square error of approximation
E. 0.966	F. 0.932	G. 0.979	H. 0.006

Regression Weights: (Group number 1 - Default model)

			Estimate	S.E.	C.R.	P
BF4	<---	BRANDFAMILIARITY	1.000			
BF3	<---	BRANDFAMILIARITY	2.099	.336	6.240	***
BF2	<---	BRANDFAMILIARITY	2.158	.359	6.018	***
BF1	<---	BRANDFAMILIARITY	1.527	.284	5.374	***
BR4	<---	BRANDRELEVANCE	1.000			
BR3	<---	BRANDRELEVANCE	.778	.087	8.922	***
BR2	<---	BRANDRELEVANCE	.546	.079	6.946	***
BR1	<---	BRANDRELEVANCE	.472	.078	6.066	***
BE3	<---	BRANDEXCLUSIVITY	1.000			
BE2	<---	BRANDEXCLUSIVITY	1.154	.086	13.456	***
BE1	<---	BRANDEXCLUSIVITY	1.066	.086	12.470	***
BP4	<---	BRANDPERFORMANCE	1.000			
BP3	<---	BRANDPERFORMANCE	.839	.114	7.392	***
BP2	<---	BRANDPERFORMANCE	.742	.097	7.640	***
BP1	<---	BRANDPERFORMANCE	.582	.108	5.409	***
BL3	<---	BRANDLEGACY	1.000			
BL2	<---	BRANDLEGACY	1.677	.337	4.975	***
BL1	<---	BRANDLEGACY	.986	.229	4.298	***
RP5	<---	REPURCHASEINTENTION	1.000			
RP4	<---	REPURCHASEINTENTION	1.658	.241	6.868	***
RP3	<---	REPURCHASEINTENTION	.901	.169	5.322	***
RP2	<---	REPURCHASEINTENTION	1.301	.206	6.308	***
RP1	<---	REPURCHASEINTENTION	1.356	.232	5.845	***
BL4	<---	BRANDLEGACY	.871	.217	4.013	***

The C.R Value obtained for all the constructs is above 1.96 and the p value is 0.000 which is as expected. This show all the five constructs of brand equity is having linear association with Repurchase intention. However, the results obtained is differing from the results of multiple regression. Though the proposed hypothesis is proved. Table 4 displays the model fit indices which shows the computed value. The CFI value is 0.96 which is above 0.9, the GFI is 0.932, the AGFI value is 0.979 which shows the proposed model is deemed to fit. The RMSEA value is 0.006 which is lesser than the expected value of 0.008. (See table 5)

VI. DISCUSSION AND CONCLUSION

Through the extensive brand equity literature, the researcher proposed the model with five constructs and hypothesis framed. The entire five hypotheses were proved using Pearson correlations and structural equation modelling analysis. The results of multiple regression are different from the results of other analysis. The Second variable of the Brand Exclusivity is having higher CR value of 13.45 which is significant. From the analysis, the researcher has found that Brand legacy is most important. Legacy speaks about the tradition of the brand. Traditional apparel brands are well patronized by the young customers. However, brand familiarity also plays an important role

in deriving a repurchase intention of the branded apparels. Brand managers are having a complex task in the years to come. Many new brands and traditional brands are competing in this dynamic scenario. Brand Relevance should be highlighted wisely. When you do any simple analysis about the successful brands around the world, those brands will be traditional and stands classic. Many brands which drives profitability are more than 70 years old and sustaining its brand value. Normally consumers will prefer generation old brand, since they would have got a word of mouth from their elders in their family. If a new brand doesn't have any tradition, apparel brand manager should create it. A brand should not only be a familiar, it should be emotionally attached with the consumers. When you look into any apparel or suit advertisement in the television, we may see some emotional touch in the advertisement which will increase the brand relevance. Next the author would like to highlight the importance of brand exclusivity. As per this study, brand exclusivity is highly boosting the repurchase intention. That's a good signage. Since apparels are associated with external personality of an individual, brand managers should stick with the fashion industry and trend of the youngsters. Of course, now itself all the brands are doing well in that part. According to the results derived from this study, all the five constructs proposed by the researcher are driving the repurchase intention of apparels. Branded stores should mandatorily look into augmented reality sections. Many forward-thinking brands are using Augmented reality to give ultimate shopping experiences which will lead to brand loyalty and repurchase intention. By just standing in front of the camera, customers may able to experience the apparel which will lead to more brand exclusivity. It is in the hands of the brand manager to sustain the brand in the minds of the consumers.

VII. SCOPE FOR FURTHER RESEARCH

Further additional research can concentrate in the areas of brand equity and impulse buying. Many of the researchers did empirical test in the area of visual merchandising and impulse buying. As a new initiative, brand equity and impulse buying may be tested. Technological components like augmented reality may be associated with brand performance and brand exclusivity.

REFERENCES

- [1] Aaker, D. A. (2009). Managing brand equity. *Simon and schuster*.
- [2] Berry, L. L. (2000). Cultivating service brand equity. *Journal of the Academy of marketing Science*, 28(1), 128-137.
- [3] Biedenbach, G., & Marell, A. (2010). The impact of customer experience on brand equity in a business-to-business services setting. *Journal of Brand Management*, 17(6), 446-458.
- [4] Cobb-Walgren, C. J., Ruble, C. A., & Donthu, N. (1995). Brand equity, brand preference, and purchase intent. *Journal of advertising*, 24(3), 25-40.
- [5] Delgado-Ballester, E., & Luis Munuera-Alemán, J. (2005). Does brand trust matter to brand equity?. *Journal of product & brand management*, 14(3), 187-196.
- [6] Erdem, T., & Swait, J. (1998). Brand equity as a signaling phenomenon. *Journal of consumer Psychology*, 7(2), 131-157.
- [7] Farquhar, P. H. (1989). Managing brand equity. *Marketing research*, 1(3).
- [8] Hoefler, S., & Keller, K. L. (2002). Building brand equity through corporate societal marketing. *Journal of Public Policy & Marketing*, 21(1), 78-89.
- [9] Ho, C., Jones, R., King, S., Murray, L., & Spence, C. (2013, May). Multisensory augmented reality in the context of a retail clothing application. In *(((ABA))) Audio Branding Academy Yearbook 2012/2013* (pp. 167-175). Nomos VerlagsgesellschaftmbH & Co. KG.
- [10] Keller, K. L., Parameswaran, M. G., & Jacob, I. (2011). Strategic brand management: Building, measuring, and managing brand equity. *Pearson Education India*.

- [11] Keller, K. L. (2001). Building customer-based brand equity: A blueprint for creating strong brands (pp. 3-27). *Cambridge, MA: Marketing Science Institute.*
- [12] Keller, K. L. (1993). Conceptualizing, measuring, and managing customer-based brand equity. *Journal of marketing, 57*(1), 1-22.
- [13] Lassar, W., Mittal, B., & Sharma, A. (1995). Measuring customer-based brand equity. *Journal of consumer marketing, 12*(4), 11-19.
- [14] Li, Y. M., & Ellis, J. L. (2014). Consumers' willingness to pay using an experimental auction methodology: applications to brand equity. *International journal of consumer studies, 38*(4), 435-440.
- [15] Park, C. W., MacInnis, D. J., Priester, J., Eisingerich, A. B., & Iacobucci, D. (2010). Brand attachment and brand attitude strength: Conceptual and empirical differentiation of two critical brand equity drivers. *Journal of marketing, 74*(6), 1-17.
- [16] Pappu, R., Quester, P. G., & Cooksey, R. W. (2005). Consumer-based brand equity: improving the measurement—empirical evidence. *Journal of Product & Brand Management, 14*(3), 143-154.
- [17] Ross, H. F., & Harrison, T. (2016, January). Augmented reality apparel: An appraisal of consumer knowledge, attitude and behavioral intentions. In *2016 49th Hawaii international conference on system sciences (HICSS)* (pp. 3919-3927). IEEE.
- [18] Srivastava, R. K., & Shocker, A. D. (1991). Brand equity: a perspective on its meaning and measurement
- [19] Wood, L. (2000). Brands and brand equity: definition and management. *Management decision, 38*(9), 662-669.
- [20] Yoo, B., Donthu, N., & Lee, S. (2000). An examination of selected marketing mix elements and brand equity. *Journal of the academy of marketing science, 28*(2), 195-211.
- [21] Yoo, B., & Donthu, N. (2001). Developing and validating a multidimensional consumer-based brand equity scale. *Journal of business research, 52*(1), 1-14.