

DSS – DRONE based SIGNAL SYSTEM

**Joseph T Joshy¹, Binet Rose Devassy², Krishnanunni M³,
Manjusha K V⁴**

Abstract

The main issue after every Man-made and Natural disaster is the breaking of the communication system. This is a severe drawback to rescue operations. Three-fourth of the time spent on rescue operations is invested in finding people. People stuck in remote places are found after many days. Many people are dead by this time. These all happen due to the unavailability of the public communication system and a proper method to locate people after the disaster. Implementation of our system in such zones can save many human lives and make life-saving procedures spontaneous. An efficient solution for citizen safety is one of the best and needy things that are required during any disasters. Thus, we introduce a unique, stable, intuitive solution for this issue- DSS! It's a system that provides GSM signal at the places of disaster, temporarily. It also helps to find the location of the people affected using mobile phone. Drone is deployed into the disaster zone where the communication is totally or partially damaged. It locates people. Signal repeaters are mounted on the drones that enable them to accept mobile signals from the nearby base stations and repeats them to the zone. Thus, people can use any cellular provider (with a nearby base station) in this repeated signal network. Using the signal provided by booster, a message is sent to the affected people's mobile number along with a link to download an app. The user now is able to install an app. Now we are able to locate them and their location is updated and displayed in the drone's webpage. When the battery of drones is about to die, it will return to an origin point set by the user for replacement. Thus, the communication network is retained and people stuck in places can be found easily.

Introduction

We introduce a unique, stable, intuitive solution for this issue- DSS! It's a system that provides GSM signal at the places of disaster, temporarily. A mesh network is created using drones at the places of disaster. GSM signal is given through these drones. People can use their mobile phones without any restrictions in this network. The mesh system created will communicate with the outside world. This system will be a great helping hand for rescue operations. Communication becomes easy and people stuck in places can be found easily. Signal boosters are devices that provide strength to a weak signal by amplifying the carrier frequency signal... So, in essence signal boosters are used to amplify network reception in weak network zones. A signal booster is a device that helps to improve the cell phone signal within an area. The description below shows how does it work:

¹ Electronics and Communication Engineering, Sahrdaya College of Engineering & Technology, Thrissur, India.

² Electronics and Communication Engineering, Sahrdaya College of Engineering & Technology, Thrissur, India.

³ Electronics and Communication Engineering, Sahrdaya College of Engineering & Technology, Thrissur, India.

⁴ Electronics and Communication Engineering, Sahrdaya College of Engineering & Technology, Thrissur, India.

- The outside antenna catches the low signal from the mobile base station and delivers it to the cell phone signal booster/repeater through the connection cable.
- After the signal is accepted by the signal booster/repeater, the device amplifies it.
- The amplified signal transmitted through the inside of the antenna to the cell phone.
- The cell phone amplifiers work at full-duplex: not only receive the low signal from the mobile base station then divert to the mobile phone after the amplification. They also receive the signal from the mobile phone then send it to a mobile base station after the amplification.

DESIGN CONSIDERATIONS

Frame Design

The frame is designed in Rhino 6 software having dimensions of the case 21x21 and having a weight of 250g. For the high perfection of the frame, the pieces are 3D printed. This particular shape is chosen for its easy portability and the legs can be adjusted so that can use less space. The fig.II.A shows the designed structure of the drone.

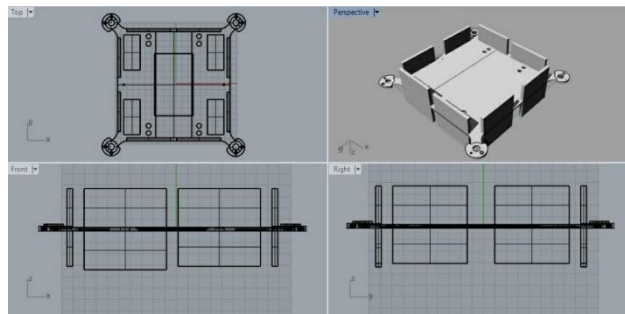

(a)

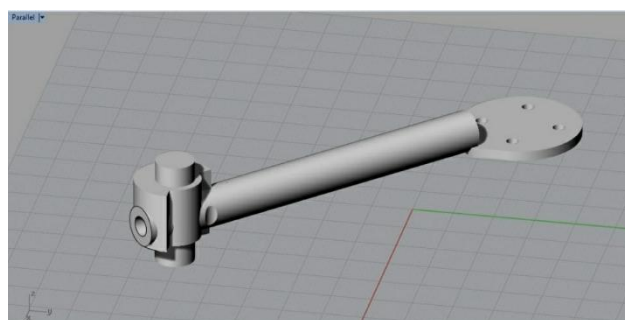

(b)

Fig.II.A (a), (b): Drone frame 3D models

B. WEIGHT

TABLE.1 COMPONENT WEIGHT CALCULATIONS

Sl. No	COMPONENTS	COUNT	WEIGHT (gm)
1	LiPo Battery 8000mAh	1	714
2	ESC 30A	1	24
3	GPS Module	1	17
4	Propellers	4	22
5	Motor	1	28
6	Frame	1	250
7	Raspberry Pi	1	60
8	Repeater	1	60
9	Current Sensor	1	15
10	Accelerometer	1	10
11	Voltage Regulator	1	15
12	ADC	1	10
	TOTAL		1381

The above *table.1* shows the weight of each component separately and the net weight is found out. This is done to know the average weight of the drone.

Circuit Design

The *Fig.II.C* shows the internal circuitry of the drone. The power is given through the raspberry pi, four brushless motors are there and ESCs are connected to each of the motors and an accelerometer is also connected with it.

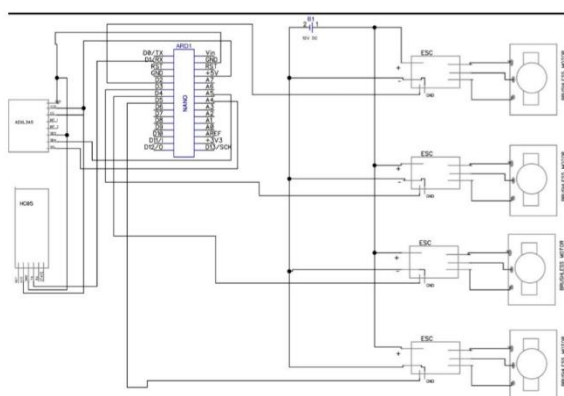

Fig. II.C Circuit Diagram

Webpage

A web page is a specific collection of information provided by a website and displayed to a user in a web browser. The homepage of web page displays four control buttons, slider, calibrate button, 4 meters and a textbox. Our webpage is working based on a database in which its values changes dynamically with sensors attached to the drone. Four control buttons are used as navigation keys which control the drone movements easily. The slider is used to adjust the height of the drone, by moving the slider up increase the drone height from the ground. There is a calibrate button by which we can calibrate the drone more accurately. We have developed an app by which we are able to track the location of people by using mobile number. The map displays the location of drone, drone user, location of affected area and also the affected people. The drone location is tracking with GPS module attached on it. We have a textbox on the bottom of the webpage in which we have to give the mobile number of affected people. The app helps to track the mobile user's location and it is given into our database, thereby their location is displayed on the map. The first two meters displayed shows the voltage and current consumed by the drone. Next two meters shows the signal strength of the receiver and transmitter, by which we are able to recognize the boosted signal strength.

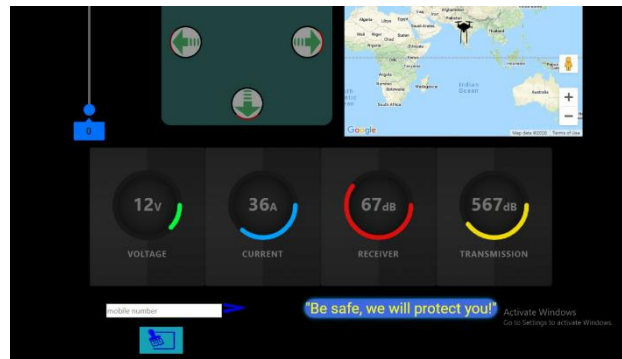

Fig. II.D Webpage

METHODOLOGY

Input-Output Section

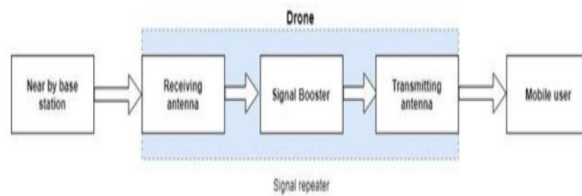

Fig.III.1(a) Block diagram of input- output Section

In emergency situations when there is a trouble in availability of signal, our drone collect signal from nearby base station to the receiving antenna and is given to signal booster. The signal gets boosted and is passed to transmitting antenna, from which it is given to mobile users.

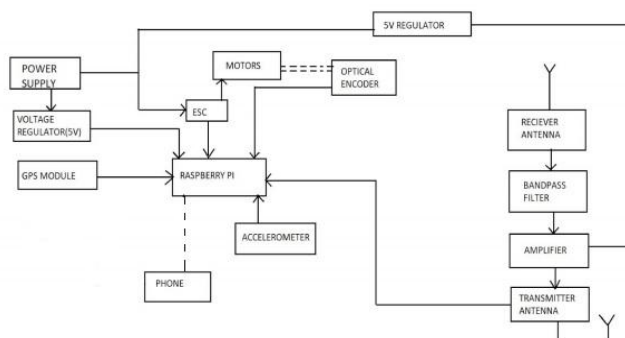

Fig.III.1(b) Block diagram of drone

Implementation

Step by step implementation procedures followed are given below:

- Step1: For the drone frame, the design of the frame structure is done using the software Rhino 6 and 3D printed the structure.
- Step 2: Weight of all components are noted separately and calculate the average weight of the drone.

- Step 3: Measuring the motor thrust using a weighing machine and with a designed apparatus, proceed to sync its speed with the rest of the motors.
- Step 4: Repeater testing is done to know the transmitted and received signal strength. Signal boosters are assembled on to the drones and tested for proper reception and boosting of signals.
- Step 5: All the components are assembled as per the circuit diagram.
- Step 6: Drone stabilization is done using the tilt angle values obtained from an accelerometer.
- Step 7: Details regarding the drone coordinates, battery strength and other aspects into a database and display it onto a webpage.
- Step 8: Two apps are created, one for sending messages to affected people and other for tracking the location of them. This location is updated to the database of the webpage and is displayed in the webpage created.
- Step 9: The above steps are repeated for any number of drones and an appropriate mesh network is made as per the disaster zone.

INTEGRATION

The final device integration involves from the bottom up:

All the components are implemented as per the circuit and obtained as shown in the *fig.IV* the booster system which is used to boost the signal receiving signal is loaded in this drone. After the integration, the drone that to deploy is ready.

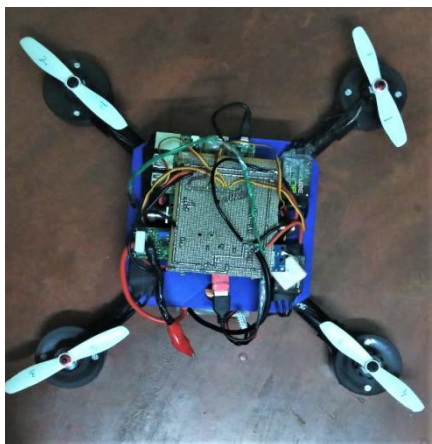

Fig.IV: Final Product

EXPERIMENTAL TESTING AND RESULTS

Thrust Calculation

Table.2: Motor Thrust calculations table and graphical representation



Thrust of each motor were calculated with our designed apparatus in order to understand the variations of speed and respective thrust of the motor and graphs were plotted with the ESC value on x axis and thrust values on the y axis. The procedure was done by providing different signal values via the esc to the motor from pi, the motor showed different thrust values for the corresponding signal value. All these values were tabulated and the above-mentioned graphs were plotted. Observing the table and graph we understood that the variation of thrust value from pi was somewhat uniform. Corresponding to this understanding the calibrations and balancing code for drones was developed.

DISCUSSION AND CONCLUSIONS

Any sufficiently advanced technology is indistinguishable from magic.” ...

Our project is DSS- Drone-based signal system, which provides GSM signal at the places of disaster, temporarily. We have successfully investigated the problem thoroughly and moved on with the prototyping works. Firstly, we have proceeded with the drone section. The component specifications are mentioned and shown in the block diagram and circuit diagram. Thrust of Each motor is calculated with a weighing machine and a designed apparatus and is given in *table.1*. Weight of each component is listed in *table.1* and thereby we calculated the overall weight of our final product. Prototyping is done based on the circuit diagram designed. We have developed a webpage along with an app which acts as an interface of our drone. Our webpage is working based on a database in which its values change dynamically with sensors attached to the drone. Four control buttons displayed on the webpage are used as navigation keys which control the drone movements easily from the ground. Now our drone is ready to be used for rescuing affected people in a disaster. The webpage designed clearly gives the location of affected people by tracking their mobile location. It perfectly boosts the signal taken from nearby base stations and gives to areas affected by disaster. The problems stated initially are perfectly solved in our project.

REFERENCES

- [1] N. Goddemeier, K. Daniel, C. Wietfeld, "Role-based connectivity management with realistic air-to-ground channels for cooperative UAVs", *IEEE J. Sel. Areas Commun.* , vol. 30, no. 5, pp. 951-963, Jun. 2012.
- [2] Y. Zeng, R. Zhang, T. J. Lim, "Throughput maximization for UAV-Enabled mobile relaying systems", *IEEE Trans. Commun.* , vol. 64, no. 12, pp. 4983-4996, Dec. 2016.
- [3] F. Jiang, A. L. Swindlehurst, "Optimization of UAV heading for the ground-to-air uplink", *IEEE J. Sel. Areas Commun.* , vol. 30, no. 5, pp. 993-1005, Jun. 2012.

- [4] Y. Sun, T. Wang, S. Wang, "Location optimization for unmanned aerial vehicles assisted mobile networks", Proc. IEEE Int. Conf. Commun. , May 2018.
- [5] J. Wang, C. Jiang, Z. Han, Y. Ren, R. G. Maunder, L. Hanzo, "Taking drones to the next level: Cooperative distributed unmanned-aerial-vehicular networks for small and mini drones", IEEE Veh. Technol. Mag., vol. 12, no. 3, pp. 73-82, Sep. 2017.
- [6] N. Rupasinghe, A. S. Ibrahim, I. Guvenc, "Optimum hovering locations with angular domain user separation for cooperative UAV networks", Proc. IEEE Global Commun. Conf. (GOLOBECOM), Dec. 2016.
- [7] A. Merwaday, A. Tuncer, A. Kumbhar, I. Guvenc, "Improved throughput coverage in natural disasters: Unmanned aerial base stations for public-safety communications", IEEE Veh. Technol. Mag., vol. 11, no. 4, pp. 53-60, Dec. 2016.
- [8] Hazim Shakhathreh, Ahmad H. Sawalmeh, Ala Al- Fuqaha, Zuochao Dou, Eyad Almaita, Issa Khalil, Noor Shamsiah Othman, Abdallah Khreishah, Mohsen Guizani – "Unmanned Aerial Vehicles (UAVs): A Survey on civil applications and key research challenge"