

SMART ROAD TRAFFIC MANAGEMENT SYSTEM

¹V.Deepak, ²Dr. Christeena Joseph

Abstract-- In this paper, the smart way of traffic control is achieved. The proposed system uses a traffic module which is connected to the Arduino, the module is implemented in a “+” junction where the quick movement of vehicles can be obtained. In the proposed system the components like Arduino mega, Traffic module, Wi-Fi module, Led (Light-emitting diodes), IR sensors are used. The system is based on IoT so that the traffic signals can be monitored continuously. This is implemented in the movement of the Ambulance during high traffic hours so that the Ambulance can reach in time to its desired location without getting stuck in the traffic for a long time also the changes in traffic module can be observed continuously.

Keywords: Traffic Management, IoT, RFID, GSM Module, IR sensors.

I INTRODUCTION

The number of commuters by their means of transport have been constantly increasing which resulted in the high traffic density especially a country like INDIA which is second highest in population the conjunction in the traffic signals is so high when compared to that in other countries because there is no updated way to control the traffic. The same time-based signals are still used in the traffic signals. These used to serve the purpose before few years because of the increase in vehicles the system needs to be changed accordingly.

Here the proposed system uses the concept of intelligence way to provide a signal which uses IR sensors which detects the traffic and provides the path for that particular lane. By this method, the movement of vehicles is much faster and the traffic conjunction can be avoided.

II LITERATURE SURVEY

Bilal Ghazal et al [1] In their work, traffic management is implemented in various ways and here the pic microcontroller is been used. The microcontroller is equipped such that it can change the signals accordingly by the usage of the IR sensor which detects the traffic density. After the detection, it sends the command to the controller if the traffic is high in one particular lane that lane is given the priority. If the traffic is less the command given is different and also it can be controlled by the traffic management authority manually. If the traffic is higher in some cases at that time it can be operated manually so that there is a precise way to manage the traffic so that the preference is given to the lane which requires the movement, also in some emergency cases like the ambulance movement is very important so it should be the first preference. But here in case of some emergency vehicles, movement the controller cant sense the vehicle in peak traffic hours .so the advanced system should be implemented to improve the traffic management.

¹ Professor, Department of CSE, RISE Krishna Sai Prakasham Group of Institutions, Ongole, AP, India, Email: ratnajoyal@gmail.com

² Professor, Department of CSE, RISE Krishna Sai Prakasham Group of Institutions, Ongole, AP, India

Kanade Pooja Rajendra et al [2] This paper proposes traffic management by using sensor nodes and other wireless devices. The main sensor which is an IR sensor senses the traffic details all the time and the information is transmitted wirelessly through some transceivers. Here the transmission takes place in two ways one is the base node and the other is the wireless way of transmission. The information about the traffic is transmitted to the baseband through a Wi-Fi system. Also, RFID (Radio-frequency identifications) are available as tags which can be used in cars based on their purpose and the RFID readers are placed near the IR sensor so that the sensing is done appropriately and tags are given to the personals based on their vehicle and the vehicles like ambulance are given with high priority tags so that they have 1st preference during emergency cases.

Amnesh goel et al [3] The main problem in the cities is the traffic, most of the cities are facing the problem of long traffic jams, to regulate the traffic the wireless sensor network (WSN) is used in this process to manage the traffic jams. Mainly sensors are used to sense the traffic, here they are of two types they are (i) Intrusive type here in intrusive type the sensors are placed under the road to measure the strength of the traffic and (ii) Non-intrusive type here the sensors are placed on the road to sense the traffic. The advantage of non-intrusive type is that the cutting of road is not required and the image processing technique is used and in some cases when whether it is not suitable this might miss behaving and the accurate readings may not be obtained this is the only disadvantage.

III OVERVIEW

The project aims to provide the signals in the case of high traffic in the lanes during peak traffic hours, suppose the traffic in a lane is so high that the vehicles have been stuck for a long time, in that case, according to the project there are IR sensors which are placed at a distance from the signal so that when the vehicles are beyond that signal the peak level is detected and the signal is provided for that lane and rest are provided with RED signal. In this way the overcome of traffic can be reduced in each lane so that the necessary lane is provided with the signal and the conjunction is avoided in that junction. This can be effective if implemented

BLOCK DIAGRAM

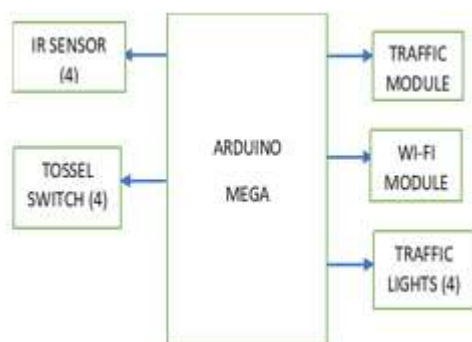

Figure 1 Block diagram of the proposed system

PROJECT DESCRIPTION

MODULE 1: In this module, IR sensors play an important role in the detection of the traffic as they are used to get the information of traffic strength to a particular distance. The sensor is placed a little far from the signal, in

this case, the effective management of traffic is been obtained. The traffic light is merged with the Arduino mega and as soon as the density is increased the signal changes according to the given command.

MODULE 2: In this module, the main and important component is Arduino as everything is connected to the Arduino. Here the Arduino is used as it is the best suited purpose and is easily understandable to all, the commands for providing signal is given in terms of code to the Arduino and based on this the signals are provided and there will be no clash of signals and precise way of monitoring can be obtained.

- A. Arduino: The Arduino Mega 2560 is a microcontroller board based on the ATmega2560. It has 54 digital input/output pins of which 14 can be used as PWM outputs and 16 analog inputs, 4 UARTs (hardware serial ports), a 16 MHz crystal oscillator, a USB connection, a power jack, an ICSP header, and a reset button. It contains everything needed to support the microcontroller simply connect it to a computer with a USB cable or power it with an AC-to-DC adapter or battery to get started.
- B. Tossel switch: The Tossel switch are similar to the normal switch these are used in circuits to turn on or turn off the power supply or in some cases, these are used to manage the controls also, the switch
- C. Traffic module: The traffic module is a simple device embedded with the traffic lights which are (Red, Yellow, green) these are embedded on a PCB board so that it is easy to connect the circuit.
- D. Wi-Fi module: It is a component that can be connected to any device and it is connected using cables. This helps to connect with the application which is used to access the data remotely. This is mainly used in all the IoT based equipment to remotely access the data and it is much convenient to use.
- E. IR sensors: An infrared sensor is an electronic device that emits to sense some aspects of the surroundings, it can measure the distance of the obstacle in its path. The ray strickled will get reflected and this will be sensed by an IR receiver. So by this, we can identify how far the object is. And the presence of an object can be identified.
- F. A. LED: LED stands for Light-emitting diode. LED glows when electricity is passed through it. LED has two terminals, the short terminal is negative and the long terminal is positive. The short terminal is known as Cathode. The long terminal is also known as Anode. LED is an PN junction diode which emits light when electricity passed in Forward based condition

IV RESULTS

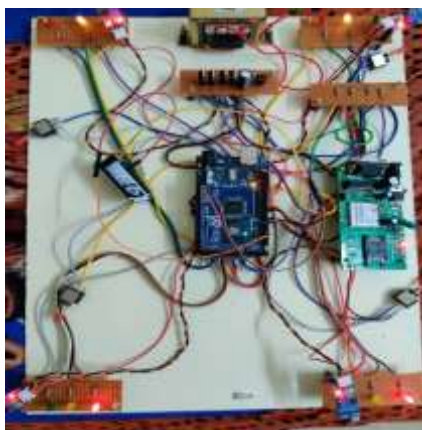

Figure 2 Result of the proposed system

V CONCLUSION

The proposed method focus on reducing traffic, manage traffic, Much importance is given to the emergency vehicles especially ambulance to provide the signal in the emergency cases the traffic operator is provided with a switch which helps to turn the signal to green in a case where an ambulance is spotted in that particular junction, so the ambulance can reach a hospital in desired time and precious lives are saved.

REFERENCES

1. Bilal Ghazal "Smart Traffic Light Control"-2016.
2. Rajendra, Kanade Pooja, and Atul Srivastava. "Traffic load minimisation using IoT." (2019).
3. Amnesh Goel, Sukanya Ray "Intelligent Traffic Light System to Prioritized Emergency Purpose Vehicles based on Wireless Sensor Network"(2012).
4. Ayush Kr. Mittal, Deepika Bhandari "A Novel Approach to Implement Green Wave system and Detection of Stolen Vehicles"(2012).
5. Mohammad S. Jassas, Abdullah A. Qasem, Qusay H. Mahmoud "A Smart System Connecting e-Health Sensors and the Cloud"(2015).
6. Dhaval Prakash Gupta, Pratyush Mishra "Accident Detection Module and IOT Based Traffic Light Control for Smooth Passage of Emergency Vehicle"(2018).
7. ADI ANIL KUMAR, GAYATRI SHENWAI "A Novel System for Traffic Control Based on Emergency Vehicle Clearance, Congestion Control and Anti-Theft Assistance"(2016).
8. Balaji Parasumanna Gokulan "Distributed Geometric Fuzzy Multiagent Urban Traffic Signal Control"(2010).
9. A. Arockia Selvaraj, K.Saminathan "Implementing Smart Control of Emergency Vehicle Using Image Processing"(2017).
10. R. Surshkumar, R. BALAJI "ADVANCED TRAFFIC CLEARANCE SYSTEM FOR AMBULANCE CLEARANCE USING RF-434 MODULE"(2016).
11. Dipti Srinivasan, Min Chee Choy "NeuralNetworksforReal-TimeTrafficSignalControl"(2006).
12. Ms. Pooja Mahajan, Ms. Harshada Jagtap "Traffic Control System"-(2018).
13. Dang-Nhac LU, Thi-Hau NGUYEN "A Novel Traffic Routing Method Using Hybrid Ant Colony System Based on Genetic Algorithm"(2017).
14. Mounib Khanafer, Mouhcine Guennoun, "WSN Architectures for Intelligent Transportation Systems"-(2009).
15. Malik Tubaishat, Yi Shang "Adaptive Traffic Light Control with Wireless Sensor Networks"(2007).
16. Maharaja, D., & Shaby, M. (2017). "Empirical Wavelet Transform and GLCM Features Based Glaucoma Classification from Fundus Image." International Journal of MC Square Scientific Research, 9(1), 78-85.
17. Saravanan, N. (2013). "Hand Geometry Recognition based on optimized K-means Clustering and Segmentation Algorithm." International Journal of MC Square Scientific Research, 5(1), 11-14.