

SPEECH RECOGNITION AND FALL DETECTION OF DOWN SYNDROME PEOPLE

¹Ch.sreenadh, ²Dr.Arasu sivagami

ABSTRACT-- Down syndrome is the common disease in the world. Due to the additional copy of 21st chromosome this particular disease will be occurring. Another name of this disease is called trisomy. For this reason the children mental and physical development is going to delay. Most of the persons affected in their entire life. But each and every people are interested to live strong and satisfying their lives. Current communication technology also plays an important role in the medical field. Many service oriented organizations help the people with Down syndrome and provide more opportunities. Fall identification and sound detection of the Down syndrome people is the most important challenge in medical field. This paper proposed a new framework to fall and sound identification using wireless techniques. The proposed system will be monitor activates and voice of the Down syndrome people. In this system uses two sensor data identify and recognize the fall. The sound sensor is used to detect the voice of the people and transfer the message to the concern taker through GSM module.

Keywords- Sound sensor, accelerometer, IoT, GPS, GSM, communication, data

I. INTRODUCTION

Based upon the National Down Syndrome Society (NDSS) survey 1 in 700 new born babies in the United States with Down Syndrome disease. In US it is major and common genetic disorder.

Down syndrome is also called as Trisomy 21. Due to chromosome abnormality the Down syndrome disease will be occurring. This disease was first recognized in 1866. The main reason of this disease is an extra copy of the 21st chromosome created while cell division. Some time copy of 21st chromosome is integrated with another chromosome during cell division process. Due to this also children are affected by Down syndrome. Down syndrome is the common genetic problem. Mother's age factor is also one of the important reasons of Down syndrome. It was identified and confirmed by using chromosome analysis only. In new born babies while blood cells are collected from their blood and diagnosis this disease by using chromosome analysis.

In current situation the healthcare domain involves many technologies used to identify and rectify the diseases in earlier stage. Continuous monitoring and recent techniques are used in newborn babies improved their surviving period. In Down syndrome people falls will direct to the very severe health issue. Fracture is the important injury of the Down syndrome people. Most of the situation falls is the major source of injury with high collision. The late medical remedies are created worst situation.

¹Dept: Electronics and communication, Saveetha School of engineering, Saveetha institute of medical and technical sciences, sreenadhchamukula@gmail.com

²Dept:NEMS/Instituteof Electronics and communication engineering, Saveetha School of engineering,Saveetha institute of medical and technical sciences, sreenadhchamukula@gmail.com

In this proposed work to improve the quality of the people affected by Down syndrome by using current communication technology IoT.

This research paper is divided into V parts. Section II describes about some existing methods were used to sound recognition and fall detection. Section III deals with proposed block diagram of sound and fall detection system. Section IV shows the result and discussion part. Section V discuss about the conclusion part.

II. LITERATURE REVIEW

Aleksey Grigore v et al., explained the emotional condition in the features voice and speech of children with Down syndrome. In this research works the authors were collected the data from 8-12 years children. Here they used three different experiment methods to identify speech. The methods are perceptual spectrographic, and linguistic. The experiments were recognized emotional condition of the children affected by down syndrome [1].

Elena Lyakso et al., used the new database “AD-Child.Ru”. This database contains 830 GB aural and videotape reports of 153 children aged between 4-16 and 20 adults with a characteristic growth. This database consists of speech samples of babies. The main aim of this database is to examine the neurological and exciting condition in the characteristics of tone and dialogue [2].

Areej Alfaraj et al., developed a tools in schools for down syndrome children in Saudi Arabia. The main objectives of the tools are guide the children affected by down syndrome disease. The teachers are trained by using the developed tools. Most of the teachers understand the various tools and gave the proper guidance to the affected children though computers, projectors, mobile phones, loud speakers etc. [3]

Jinjuan Feng et al., said that children affected with Down syndrome not having the exposure of computer terminologies. But computers and computer-related peripherals are really help the children affect by Down syndrome disease in teaching, career growth, and self-governing livelihood. Most of the computer websites and games are constructed without any concerns of the children affected by Down syndrome. So the down syndrome peoples are not able to use and access the web sites and games. The authors are conducted a survey around 600 children affected with Down syndrome regarding computer usage data. The result of the survey showed the association connecting the age and the precise type of problems as well as connected implementation challenges [4].

Brian G. Skotko, et al., studied Down syndrome people with the age 12. According his survey 99% of people with Down syndrome that they were happy with their existing life. They had shown their love to their family members like brothers and sisters. 86% of the people make the relationships with their friends easily. Less percentage of the peoples shows their sadness. Finally the authors said that most of the children affected by Down syndrome live happily with their family members [5].

Falin Wu et al., developed a fall detection system using tri axial accelerometer based on wearable devices. The proposed system used accelerometer to be set permanently. This system consumes very less power and using high well organized algorithm strictly. The hardware and the software implementation are sued for wearable and outside use. Apart from this techniques SVM and neural network are find out proper classification technology used by this system [6].

Meagan Smith et al., said that Down syndrome is the important cause of prenatal genes abnormalities. The disease was identified by using anatomical ultrasound, maternal serum screening, and noninvasive prenatal testing. In this paper the authors reviews all currently available noninvasive diagnostic techniques to detect the disease of Down syndrome. According to the physicians directions parents take care of their children affected by disease [7].

H. Mizuno et al., constructed a wearable sensor system used to identify human behavior. This system used several attributes like in foot, running, status, intake, chatting, and desk work. This proposed system consists of various devices and sensors. All the devices are connected through wireless network communication [8].

Faisal Hussain et al., explains falling is a cruel problem in elderly people. Due to fall the people are going to costly treatments and it extended to large amount of time sometime time it leads with death also. Sensors are used to monitor the people continuously. In this paper proposed a new system for falls monitoring. The output of the given system was analyzed using various machine learning algorithms such as, namely, k-nearest neighbors (KNNs), support vector machine, and random forest (RF). The accuracy of the proposed system was 96.82% using RF classifier [9].

Chaccour, K et al., describes all are a important health issue for the elder people community. Now large number of research is going in the particular field. In this study tackled the issue when the fall occurring time using various sensors. After that the author put their effort to prevent the fall before it will occur [10].

III. PROPOSED SYSTEM

The following figure 1 shows a block diagram of proposed system. Here all the sensors are connected using Arudunio Controller. The sound of the down syndrome people is sensed by sound sensor and the movements of human body is detected by acceleration sensor. The sensed data passed to the care taker by using GSM and GPS modules.

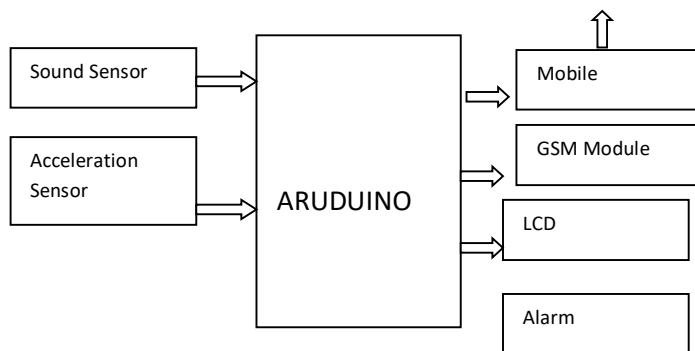

Figure 1: Block diagram of Proposed System

IV. RESULTS AND DISCUSSION

The principle of this system is to identify human body parameter signals and sounds from the different sensors to the controller. The sound detector and the mems sensor are placed with the Down syndrome person. Whenever that person gives any sound or falls down from the bed immediately a message and call will go to the concerned

person to help him. The buzzer is used give the alert to the care takers. The following figure shows the flow of control between various devices using GSM.

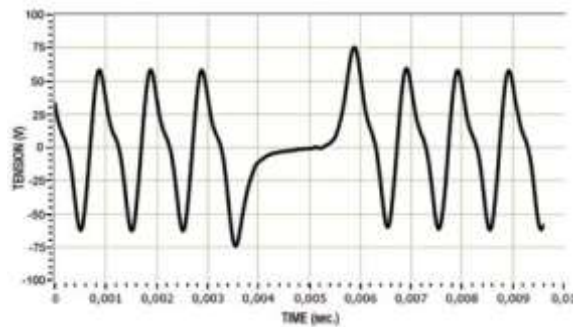

Figure 2: Graph of sound detector

V. CONCLUSION

Down syndrome people in today's world need a specific assistance. All are busy with each work so they find very difficult to help their Down syndrome person. In our proposed system we are using sound detector and mems sensor. Whenever the sound is been produced by the person or if he falls down the concerned person is been alerted by sending an SMS through GSM and he can be assisted anytime.

REFERENCES

1. Lyakso, E., Frolova, O., Gorodnyi, V., Grigorev, A., Nikolaev, A., & Matveev, Y(2019), " Reflection of the Emotional State in the Characteristics of Voice and Speech of Children with Down Syndrome" International Conference on Speech Technology and Human-Computer Dialogue (SpeD).
2. Lyakso, E., Frolova, O., & Karpov, A. (2018), " A New Method for Collection and Annotation of Speech Data of Atypically Developing Children" 2018 International Conference on Sensor Networks and Signal Processing (SNSP), pp.175-180.
3. Arabia Areej Alfarajl & Ahmed Bawa Kuyini(2014), "Use of Technology to Support the Learning of Children with Down Syndrome in Saudi ", World Journal of Education Vol. 4, No. 6; ISSN 1925-0746, pp-42-53.
4. JINJUAN FENG & JONATHAN LAZAR(2010), "Computer Usage by Children with Down Syndrome: Challenges and Future Research", ACM Transactions on Accessible Computing, Vol. 2, No. 3.
5. Brian G. Skotko, Susan P. Levine & Richard Goldstein(2013), "Self-perceptions from People with Down Syndrome" PubMed.
6. Falin Wu , Hengyang Zhao , Yan Zhao & Haibo Zhong (2015), "Development of a Wearable-Sensor-Based Fall Detection System" , International Journal of Telemedicine and Applications
7. Meagan Smith & Jeannie VisootsakInt J (2013), "Noninvasive screening tools for Down syndrome: a review", Womens Health, pp 125–131.
8. Mizuno, H., Nagai, H., Sasaki, K., Hosaka, H., Sugimoto, C., Khalil, K., & Tatsuta, S. (2007), "Wearable Sensor System for Human Behavior Recognition", International Solid-State Sensors, Actuators and Microsystems Conference, pp.435-438.

9. Hussain, F., Hussain, F., Ehatisham-ul-Haq, M., & Azam, M. A. (2019), “ Activity-Aware Fall Detection and Recognition based on Wearable Sensors” . IEEE Sensors Journal, pp. -4528- 4536.
10. Chaccour, K., Darazi, R., El Hassani, A. H., & Andres, E. (2017), “ From Fall Detection to Fall Prevention: A Generic Classification of Fall-Related Systems. IEEE Sensors Journal, 17(3), pp. 812–822.
11. Jha, S. K., & Chauhan, A. (2019). Sharing image through visual secret sharing scheme using speech recognition method. International Journal of Advanced Science and Technology, 28(16), 303-307. Retrieved from www.scopus.com
12. Singla, C., & Singh, S. (2019). Databases, classifiers for speech emotion recognition: A review. International Journal of Advanced Science and Technology, 27(1), 69-76. Retrieved from www.scopus.com