

THE RELATIONSHIPS AMONG JOB SATISFACTION, EMOTIONAL EXHAUSTION, CYNICISM, JOB ENGAGEMENT AND CREATIVE WORK INVOLVEMENT, STUDY ON EDUCATION INSTITUTIONS IN INDONESIA

¹Heni Kusumawati, ²Wisnu Prajogo, ³Nikodemus Hans Setiadi Wijaya

ABSTRACT--*This study examines the relationship between job satisfaction, cynicism, emotional exhaustion, job engagement and creative work involvement. This study used 200 respondents who came from educative and non-educative workers in Indonesia. The research data have fulfilled the validity, reliability and normality tests. Hypothesis testing uses the Structural Equation Model (SEM) with Confirmatory Analysis. The results showed that job satisfaction positively influences on work engagement at $\alpha = 1\%$, while emotional exhaustion has no influence on the direction of the negative relationship to job engagement. The cynicism variable has no significant influence on job engagement with the direction of a positive relationship. While the variable job engagement positively influences creative work involvement at $\alpha = 1\%$.*

Keywords-- *Job Satisfaction, Cynicism and Creative Work Involvement*

I. INTRODUCTION

Higher education institutions as organizations with open systems have to adapt and respond to environmental changes both internal and external environment. Every activity is directed at the learning process because essentially tertiary education is a learning organization. The paradigm of organizational change in the technology era 4.0 requires every member of the organization to have strong competitiveness. Likewise in the world of education in Indonesia, currently experiencing global change. The need to innovate through information technology requires educators and administrative staff to contribute creatively to the world of work. Optimal employee involvement supported by direction from organizational leaders will motivate employees to create innovative ideas in continuous organizational improvement.

¹YKPN Business School, Yogyakarta, Indonesia, heni.kusumawati89@gmail.com.

²YKPN Business School, Yogyakarta, Indonesia, wisnuprajogo@gmail.com.

³YKPN Business School, Yogyakarta, Indonesia, niko.wijaya@gmail.com.

Increasing the role of technology causes an increasingly limited scope of work scope. Job demands are higher and more repetitive jobs can be replaced by machines or robots. Organizational change with high work pressure raises concerns for employees about current job positions. Work pressure and conditions of uncertainty encourage instability and emotional exhaustion of a person which causes a lack of involvement in work. Emotional fatigue is described as the inability of individuals to offer themselves more emotionally to themselves.

Organizational failure to meet the expectations of members of the organization will cause disappointment and allow employees to have a cynical attitude. As a consequence of cynicism, it can lower organizational commitment, motivation, or satisfaction as well as lowering the commitment to the organization. The negative impact on employees, that cynicism can reduce a person's involvement in his work.

II. LITERATURE REVIEW AND HYPOTHESES

1.1. Relationship between Job Satisfaction and Job Engagement

Locke and Latham (1990) in (Grama, Blanca Girgina and Botone, Daniela Nicoleta, 2016), suggest a resolution of satisfaction with pleasant working conditions, based on one's work experience. Job satisfaction will be perceived as a pleasant experience and provide important things in the work. Job satisfaction reflects positive results supported by conducive workplaces. Job satisfaction in educational institutions can increase participation in research such as increasing the efficiency of teaching in the classroom, increasing the amount of research and community service activities. While in administration, job satisfaction can be received with work commitments, replace the achievement of results in accordance with work instructions and decrease the level of errors in work.

High involvement employees are characterized by a high level of autonomy, a higher level of control over the work, and ethical behavior and dedication to the company. Job satisfaction affects how an employee can be fully involved in his work. Job satisfaction positively correlated with employee involvement. Women workers have a higher involvement than men in creating creative ideas (Jaswanti, V.P and Priya D., 2019).

While in the study of Tepayakul and Rinthaisong (2018), in research at educational institutions in Thailand, organizations need to provide driving factors both intrinsic and extrinsic factors to the administrative staff to create alignment of employee job satisfaction, with organizational strategy, employee empowerment, teamwork, and collaboration. It is expected that job satisfaction is able to encourage growth, development and recognition of work for their involvement. The more enthusiastic workers were, the better the results of the operations they achieved for the company. Employee involvement has a positive and significant relationship with job satisfaction. Empirically, no differences were found in the gender of the respondents in relation to work involvement (Vorina, A., Simonc, Miro and Vlasova, M., 2017). Therefore, we define the first hypotheses:

Ha1: Job Satisfaction has a positive effect on Job Engagement

1.2. Relationship between Emotional Exhaustion and Job Engagement

Emotional exhaustion is triggered by work demands. The challenge of managing millennial students in tertiary institutions with technology requirements demands the full involvement of education personnel. Teachers and administrative staff must respond quickly to every student's needs. This often leads to emotional clarity.

In this case, job demands will result in emotional fatigue and lower work involvement for employees. Work demands, resource demands, and personality drive the emergence of emotional exhaustion and work involvement. There is a negative relationship between the variables of emotional exhaustion and employee performance. (Crospanzano, R., Rupp, Deborah E. and Byrne, Zinta S., 2003). Furthermore, the personal accumulation of emotional exhaustion will have an impact on overall organizational performance. Therefore, we define the third hypotheses:

Ha2: Emotional Exhaustion has a negative effect on Job Engagement

1.3. Relationship of Cynicism and Job Engagement

Organizational cynicism has a negative correlation with work involvement. The higher the level of cynicism, the lower a person is actively involved in the organization (Yasin, Tahreem and Khalid, S., 2015). Cynicism towards organizations can be shown by being suspicious, distrustful, disparaging to the organization and psychologically inclined to separate from the work environment.

The three aspects of organizational cynicism (Grama, Blanca Girgina and Botone, Daniela Nicoleta, 2016) are (1) the belief that the organization has no integrity; (2) negative feelings towards the organization and (3) a tendency to behave negatively towards the organization, according to the beliefs and feelings of the individual. Cynical employees not only develop negative emotions towards the organization where they work, but also have a negative impact on work in general, on their supervisors and coworkers, and the work environment. Very important for organizations to lower the level of organizational cynicism, because it can trigger employees to have negative emotions and behaviors towards the organization, resulting in a decrease in job satisfaction and lack of involvement at work (Sulea, Coralia., et. al, 2012).

The influence of organizational cynicism on work involvement, age and seniority of employees in Romanian private companies. Organizational cynicism occurs when employees have low commitment and integrity. The lack of integrity felt by employees can be caused by organizational failure to meet employee expectations in terms of honesty and fairness (Grama, Blanca Girgina and Botone, Daniela Nicoleta, 2016).

The level of employee involvement varies by industry. Productivity focus becomes obvious today as organizations facing technological and economic pressure has to stay productive. This condition makes the organization accidentally ignores staff involvement issues and focus their effort to reduce costs and develop projects to grow and survive. In the end, many staff are frustrated and become less creative and innovative. This lowers an organization's ability to compete and adapt to a changing environment. Therefore, we define the fourth hypotheses:

Ha3: Organizational cynicism has a negative effect on Job Engagement

1.4. Relationship between Job Engagement and Creative Work Involvement

Workplace creativity and innovation is the process, results, and products of efforts to get things done in a new way to achieve higher productivity. The first phase begins with the generation of ideas, while innovation refers to the next stage of implementing ideas towards better procedures, practices, or products Creativity and innovation can occur at the level of individuals, work teams, organizations (Anderson, N., Potocnik, K. and Zhou, K., 2014).

Creativity as the ability to generate new and innovative ideas, which benefit many communities for survival and improve organizational competitiveness (Gichohi, Paul Maku, 2014). His empirical study of library staff in Kenya described work involvement as having an important role in the initial stages of creating creativity and innovation. Human resources are the main input of creativity and innovation, but they cannot run it if they are not involved in a job they are interested in.

Employee involvement is the level at which workers feel job satisfaction and emotional connection to organizational success. Employee involvement reflects the level of commitment and sincerity of employees in carrying out organizational tasks based on the values they believe (Sundaray, B.K, 2011). Employees who are not fully involved in work tasks become an obligation for the organization and tend not to challenge the status quo. While employees who are involved in work assignments, show emotional attachment to the work for which they are responsible, have an unconditional commitment, worked hard to increase productivity and high enthusiasm.

Organizational culture will determine the organization's ability to foster creativity and innovation. Culture is developed in stages by providing facilities, incentives, a conducive working atmosphere, and leadership. To be creative that enable employees to generate new ideas, employees will need good leadership. Leaders should exercise empathy, consideration, support, and should help employees to overcome the fear challenge (Gong, Yaping., Huang, JP and Farh, J., 2009). The key role of transformational leadership in maintaining a creative environment through providing an atmosphere of learning, delegating and encouraging follower autonomy. Creativity and innovation behavior is based on intrinsic motivation. The role of intrinsic motivation forms a conducive environment for creating creativity. Organizational drive that is manifested by leadership behavior and style influence the work character of employees who are creative and innovative (Gichohi, Paul Maku, 2014). Work involvement is able to partially mediate the relationship between cynicism, work fatigue and intention to move to other workplaces (Mangi, Riaz Ahmed and Jalbani, A., 2013). Therefore, we define the second hypotheses:
Ha4: Job Engagement has a positive effect on Creative Working Involvement

III. RESEARCH METHODOLOGY

3.1. Research Data and Samples

The population of this research is education and non-education personnel in higher education institutions in Indonesia, both at state and private universities. The research sample of 200 respondents at universities in the region of Central Java, East Java, and Greater Jakarta. The reason for taking the sample is done in tertiary institutions with the level of use of information technology that is more advanced in the operation of the education system.

This study uses quantitative surveys that are supported by in-depth interviews in measuring the level of employee involvement. Quantitative data were obtained by distributing questionnaires to respondents in May-June 2019, with a Likert scale of 1-5. While qualitative data is needed because the driving force for unique employee involvement in an organization not only determined by looking at the number of frequencies and percentages only. Interviews were conducted in August 2019 with educative and non-educative staff on samples domiciled in Yogyakarta, due to time constraints and travel locations for researchers.

3.2. Conceptual Framework

This research empirically to proves the relationship between the variables of the perception of positive and negative attitudes of educative and non-educative personnel including Job Satisfaction, Emotional Fatigue and Cynicism on Work Engagement behavior. Likewise, the researcher wants to obtain empirical evidence about the effect of the relationship of Work Involvement on Creative Work Involvement. The research framework can be seen in the following chart:

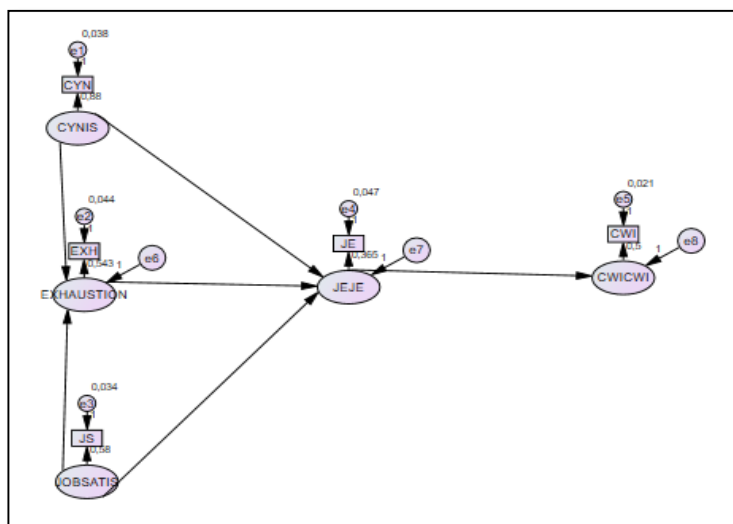

Figure 1: Research Conceptual Framework

IV. RESULTS AND FINDINGS

The validity and reliability requirements of the research data were fulfilled, with correlated validity values above 0.3 and Cronbach's Alpha values > 0.6. So it can be stated that the research variables consist of Job Satisfaction, Emotional Fatigue, Cynicism, Work Engagement and Creative Working Involvement are valid and reliable. All research variables have also passed the normality test so that it can then be continued on hypothesis testing.

Table 1: Test Results of Validity and Reliability of Research Data

Variabel	Coefficient correlation $r > 0.3$	Validity Status	Cronbach Alpha > 0.6	Reliability Status
Sinisme (CYN)	0.764	Valid	0.952	reliable
Emotional Exhaustion (EXE)	0.577	Valid	0.867	reliable
Job Satisfaction (JK)	0.632	Valid	0.865	reliable
Job Engagement (JEJ)	0.623	Valid	0.801	Reliable
Creative Working Involvement (CWI)	0.667	Valid	0.919	Reliable

Source: Research Data. Processed 2019

Based on the criteria of goodness of fit, the test results show that the research model is declared good, it can be recommended further research pigs. The results of testing the research model can be presented in table 2 below

Table 2: Results of Testing the Research Model

The goodness of Fit Index	Criteria	Result	Model Evaluation
Chi-Square	Small, not significant	0.00	Good fit
CMN	≤ 2.00	1.83	Good fit
GFI	≥ 0.90	0.99	Good fit
AGFI	≥ 0.90	0.99	Good fit
TLI	≥ 0.90	1.02	Good fit
CFI	≥ 0.95	1.00	Good fit
RMSEA	≤ 0.08	0.00	Good fit

Source: Research Data. Processed 2019

Based on a statistical description analysis, a summary of the results can be obtained as follows:

Table 3: Descriptive Analysis of Research Variables

	N	Minimum	Maximum	Mean	Std. Deviation
Age	200	1	5	2.82	1.11
Gender	200	1	3	1.41	0.50
Marital	200	1	2	1.14	0.34
Education	200	1	6	2.33	1.28
Working Status	200	1	3	1.99	0.44
Income	200	1	4	1.77	0.85
ACyn	200	1.00	5.00	2.69	0.94
AJS	200	2.33	5.00	3.97	0.65
AEX	200	1.00	5.00	2.09	0.68
ACWI	200	2.22	5.00	3.57	0.60
AJEJ	200	2.67	5.00	3.84	0.49
Valid N (listwise)	200				

Source: Research Data. Processed 2019

The demographic characteristics of respondents in the study, in the age range of 40 - < 50 years, with the majority of female sex and most are married. Based on the educational background for education personnel is Master Program and, Diploma Program for administration staff. The attitudes characteristics of respondents have a perception of enough cynicism (mean = 2.685) towards the organization where they work, the average respondent

expressed satisfaction in their work (Mean = 3.973), a sufficient level of emotional exhaustion low (Mean = 2.09), high level of creative involvement (Mean = 3.571) and high work involvement (Mean = 3.845).

By the Structural Equation Model (SEM) test with two-step confirmatory analysis, a summary of the results is obtained as follows:

Table 4: Research Hypothesis Testing Results

Path Analysis	Estimate	Standar Error	Coefficient	Sign	P-Value	Keterangan
JE ← JS	0.43	0.06	7.28	Positive	0.00***	Ha1 supported
JE ← EXH	-0.12	0.05	-2.25	Negative	0.024**	Ha2 supported
JE ← CYN	0.06	0.03	1.93	Positive	0.053*	Ha3 not supported
CWI ← JE	0.98	0.13	7.44	Positive	0.00***	Ha4 supported

Source: Research Data. Processed 2019

Note: * significant at $\alpha = 10\%$, ** significant at $\alpha = 5\%$, *** significant at $\alpha = 1\%$

This research support hypothesis 1 which states job satisfaction has a positive effect on Work Involvement ($\beta = 7.283$, $P < 0.01$). The higher the level of job satisfaction of educative and non-educative staff, will increase the personal involvement of members of the organization in every job. This research also supports hypothesis 2 which states that emotional exhaustion has a negative effect on work involvement of employees ($\beta = -2.251$, $P < 0.01$). It can be concluded that employees with lower emotional levels will encourage those involved to be more actively involved in the work for which they are responsible for the organization. This research can not support hypothesis 3 which states that organizational cynicism has a negative effect on work engagement ($\beta = 1.934$, $P > 0.01$). This is due to the relationship between the two variables showing a positive direction, so it does not support the proposed hypothesis. The results of this study contradict the findings of previous studies namely (Gramma, Blanca Girgina and Botone, Daniela Nicoleta, 2016), and (Sulea, Coralia., et. al, 2012), which states that Cynicism variables negatively affect Work Engagement. This phenomenon is in line with a descriptive analysis of cynic variables, that the characteristics of respondents, in general, are less cynical about the organization so that the attitudes expressed to participate in organizational activities are well revoked and trust in the organization. This research support hypothesis 4 which states that Work Involvement has a positive effect on Creative Work Involvement ($\beta = 7.440$, $P < 0.01$). This shows that employee engagement behavior encourages personal to act creatively and is able to express creative ideas in new innovations. This makes the competitiveness of universities to be able to survive in global change, especially in the world of education.

REFERNCES

1. Ali, S., nad Farooqi, Y.A. (2014). Effect of work overload on job satisfaction, the effect of job satisfaction on employee performance and employee engagement (A case of public sector university of Gujranwala division). *International Journal of Multidisciplinary Sciences and Engineering*, 23-30.

2. Anderson, N., Potocnik, K. and Zhou, K. (2014). Innovation and Creativity in Organizations: A State of the Science Review and Prospective Commentary. *Journal of Management*, 1297-1333.
3. Arslan, Muhammad and Roudaki, Jamal. (2019). Examining the role of employee engagement in the relationship between organizational cynicism and employee performance. *International Journal of Sociology and Social Policy*, 118-137.
4. A. Y. Alzyoud, Adel, Z. Othman, Siti and Isa, Mohd F. (2015). Examining the Role of Job Resources on Work Engagement in the Academic Setting. *Asian Social Science*, 103-110.
5. Bang, Hyejin and Reio, Thomas G. Jr. (2017). Examining the role of cynicism the relationship between burnout and employee behavior. *Journal of Work and Organizational Psychology*, 217-227.
6. Baniya Chhetri, Sabina. (2017). Predictors and Outcomes of Employee Engagement: Empirical Study of Nepali Employees. *Journal of Business and Management Research*, 14-32.
8. Crospanzano, R., Rupp, Deborah E. and Byrne, Zinta S. (2003). The Relationship of Emotional Exhaustion to Work Attitudes, Job Performance, and Organizational Citizenship Behaviors. *Journal of Applied Psychology*, 160-169.
9. Esfandiari, Rajab and Kamali, Mahdi. (2016). On the relationship between job satisfaction, teacher burnout, and teacher autonomy. *Iranian Journal of Applied Language Studies*, 1-26.
10. Gichohi, Paul Maku. (2014). The Role of Employee Engagement in Revitalizing Creativity and Innovation at the Marketplace: A survey of selected libraries in Meru County - Kenya. *Library Philosophy and Practice*, 1-33.
11. Gong, Yaping., Huang, JP and Farh, J. (2009). Employee Learning Orientation, Transformational Leadership, and Employee Creativity: The Mediating Role of Employee Creative Self-Efficacy. *Academy of Management Journal*, 765-778.
12. Grama, Blanca Girgina, and Botone, Daniela Nicoleta. (2016). The relationship between work engagement, Organizational Cynicism and Job Satisfaction in A Romania Private Company. *Journal of Education and Learning*, 108-116.
13. Jaswanti, V.P and Priya D. (2019). Relationship between Job Satisfaction and Employee Engagement among teachers in Chennai. Research Gate, 1-7.
14. Kim, Woocheol, et al. (2017). The Relationship Between Work Engagement and Organizational Commitment: Proposing Research Agendas Through a Review of Empirical Literature. *Human Resource Development Review*, 350-376.
15. Klusmann, Uta, et al. (2008). Engagement and Emotional Exhaustion in Teachers: Does the School Context Make a Difference? *Applied Psychology*, 127 - 15
16. Mangi, Riaz Ahmed and Jalbani, A. (2013). Mediation of Work Engagement Between Emotional Exhaustion, Cynicism and Turnover Intentions. *International Journal of Management Sciences Research*, 45-54.
17. Olsen, Amanda A., and Francis L. Huang. (2019). Teacher Job Satisfaction by Principal Support and Teacher. *Education Policy Analysis Archives*, 1-7.
18. Paveloni, Anca and Delia Virga. (2019). The impact of cynicism and ethical intentions on organizational attitudes: work engagement, job satisfaction, and organizational citizenship behavior. *Psihologia Resurselor Umane*, 28 - 44.

19. Srivastava, Abhishek & John W. Adams, (2011). Relationship Between Cynicism and Job Satisfaction: Exploration of Mechanisms. *Psychological Reports*, 108(1), 27-42.
20. Shuck, M.B and Reio, T.G., Jr. (2014). Employee engagement and well being: A moderation model and implications for practice. *Journal of Leadership and Organizational Studies*, 43-58.
21. Sulea, Coralia., et. al. (2012). Work engagement as mediator. *Career Development*, 188-207.
22. Sundaray, B.K. (2011). Employee Engagement: A Driver of Organizational Effectiveness. *European Journal of Business and Management*, 53-60.
23. Vorina, A., Simonic, Miro and Vlasova, M. (2017). An Analysis of the Relationship between Job Satisfaction and Employee Engagement. *Journal Economic Themes*, 243-262.
24. Wright, T. A., and Cropanzano, R. (1998). Emotional Exhaustion as a Predictor of Job Performance and Voluntary Turnover. *Journal of Applied Psychology*, 486-493.
25. Yasin, Tahreem and Khalid, S. (2015). Organizational Cynicism, Work-Related Quality of Life and Organizational Commitment in Employees. *Pakistan Journal of Commerce and Social Sciences*, 568-582.
26. Yim, Joanne Sau-Ching & Priscilla Moses. (2016). Work factors and teacher satisfaction:
27. The mediating effect of cynicism toward Educational Change. *Issues in Educational Research*, 694-709